

2000BS DIGITAL PANEL VOLTMETER

03110

This documentation may not be copied, photocopied, reproduced, translated, or reduced to any electronic medium or machine-readable form, in whole or in part, without prior written consent of NEWPORT ELECTRONICS, INC.

© Copyright 1993 NEWPORT ELECTRONICS, INC. ALL RIGHTS RESERVED.

CHG	ECO NO	DATE	BY	CHK
J	6832	19 SEP 90	MV	

TABLE OF CONTENTS

1.0	GENERAL INFORMATION	1
1.1	Description	1
1.2	Specifications	2
2.0	RECEIVING AND INSTALLATION	5
2.1	Unpacking and Inspection	5
2.2	Installation-Mechanical	5
2.3	Initial Checkout Procedure	6
3.0	OPERATING INSTRUCTIONS	7
3.1	Power	7
3.2	Signal Inputs	9
3.3	Input Characteristics	11
3.4	Digital Input/Outputs	12
3.5	2000BS Pin Assignments	17
4.0	THEORY OF OPERATION	19
4.1	General	19
4.2	Timing	19
5.0	MAINTENANCE AND CALIBRATION	23
5.1	Introduction	23
5.2	Calibration	23
5.3	Maintenance and Repair	24

ILLUSTRATIONS

Figure 2-1	Rear-View Interconnect	6
Figure 3-1	115 V ac Connection	8
Figure 3-2	230 V ac Connection	8
Figure 3-4	Input Signal Connections	10
Figure 4-1	Simplified Timing Diagram	19
Figure 4-2	Simplified Block Diagram	21
Figure 4-3	Timing Diagram 2000BS	21
Figure 5-1	Rear-View Calibration Adjustment Location	24
Figure 5-2	Assembly - PCB, 2000BS Analog	26
Figure 5-3	Schematic - PCB, 2000BS Analog	27
Figure 5-4	Assembly - PCB, 2000BS Digital	28
Figure 5-5	Schematic - PCB, 2000BS Digital	29
Figure 5-6	Outline and Mounting	30

SECTION 1
DESCRIPTION

1.1 General

For applications of up to 0.005% resolution, the Series 2000B/S offers a low-cost, reliable approach to digital display of analog voltages and currents. Series 2000B/S digital panel meters provide up to +19,999 count readings of any of four DC voltage and four DC current ranges. Using highly-stable integrating techniques, the Series 2000B/S can complete from 4 to 30 readings per second. Upon command, all Series 2000B/S DPM's will hold a reading indefinitely. True differential inputs, isolated from power line, case and BCD grounds, prevent ground-loops and tedious system trouble-shooting.

Series 2000B/S meters allow the decimal point to be set externally to any one of four positions. The BCD outputs and the external control inputs and outputs are compatible with TTL and DTL for ease in interfacing with other instruments.

The gated BCD output forms a digital multiplexer, so the BCD lines of several DPM's may be parallel-wired and multiplexed to a common recorder. Each DPM is sequentially enabled and its BCD data appears on buss lines driving the recorder. Buffer amplification makes it impossible for noise on the BCD outputs to affect the reading stored in the DPM.

Decimal point location and encode rate can be remotely controlled. All outputs are IC compatible. For ruggedness and shielding against external noise, the 2000B/S is housed in an extruded aluminum case.

1.2 Specifications

DC VOLTAGE METERS				
Model	2000B/S-1	2000B/S-2	2000B/S-3	2000B/S-4
Full Scale	$\pm 199.99\text{mv}$	$\pm 1.9999\text{V}$	$\pm 19.999\text{V}$	$\pm 199.99\text{V}$
Resolution	10uv	100uv	1mv	10mv
Impedance, min.	1G Ohm		10M Ohm	
Input Current Max.	10nA Bias 2nA Offset		-	
Maximum Overdrive	150V		500V	
Maximum Error 8 hr at 25°C	.01%R $\pm .02\%FS$.01%R $\pm .01\%FS$.01%R $\pm .015\%FS$.01%R $\pm .01\%FS$
Maximum Error 15-35°C, 30 days	.02%R+ $.03\%FS$.02%R+ $.02\%FS$.03%R $\pm .02\%FS$	
Temperature Stability 0 to 15°C and 35 to 55°C	(.002%R $\pm .002\%FS$) Per °C	(.0015%R $\pm .001\%FS$) Per °C	(.002%R $\pm .002\%FS$) Per °C	(.002%R $\pm .0015\%FS$) Per °C

DC CURRENT METERS				
Model	2100B/S-2	2100B/S-3	2100B/S-4	2100B/S-5
Full Scale	$\pm 199.99\text{ua}$	$\pm 1999.9\text{ua}$	$\pm 19.999\text{ma}$	$\pm 199.99\text{ma}$
Resolution	10na	100na	1ua	10ua
Voltage Drop	200mv, full scale			
Maximum Overdrive	10ma	30ma	100ma	500ma
Maximum Error 8 hr at 25°C	.02%R $\pm .02\%FS$			
Maximum Error 15-35°C, 30 days	$\pm .05\%R \pm .03\%FS$			
Temperature Stability 0 to 15°C and 35-50°C	$(.003\%R + .002\%FS)/\text{°C}$			

Internal Read Rate	4/sec to 30/sec programmable by external resistance
Settling Time	After full scale step input, to within .01% of final answer, 250ms standard; from 2ms to 2 sec on special order
Normal Mode Rejection	20 db (60 Hz) with standard filter; up to 37 db available by increasing settling time (consult factory)
Polarity	Automatic
Common Mode Rejection, DC to 60 Hz	
To power line, case	100 db
To BCD common	80 db
Common Mode Voltage, to meet CMR Specification, (either input for 200mV & 2V)	
To power line, case	300 volts
To BCD common	6 volts
Remote Controls	BCD enable and reading hold
Calibration	Full scale and zero pots accessible from rear panel
Operating temperature range	0 to 55°C
Storage temperature range	-40 to +80°C
Display	0.55-inch, 7 segment, planar, gas discharge, numerals with + and - indicators
Overload Indication	Four least significant digits blank.
Power	115/230 VAC \pm 10%, 50 to 60Hz, 7 watts
Enclosures	2.2" high x 4.35" wide x 4.9" deep with connector, extruded aluminum case; bezel (option A3) has removable name plates for replacement by customer nomenclature.
Weight	Less than 3 pounds, net; 5 pounds, shipping.

CONNECTOR TYPES (Option D2)

Analog Connector SAE No. SAC 10D/1-2 or
 CINCH NO. 251-10-30-160

Digital Connector SAE No. SAC 15D/1-2 or
 CINCH No. 251-15-30-160

Key SAE No. 007900 or
 CINCH No. 456-99-99-193

Connector Key Position

Analog Connector between pin 3 and pin 4

Digital Connector between pin 11 and pin 12

SECTION 2

RECEIVING AND INSTALLATION

2.1 Unpacking and Inspection

Your Series 2000B/S digital panel meter has been carefully inspected and tested before shipment. Unpack the meter and perform a visual inspection to assure that no damage has occurred during shipment or handling. These meters are factory sealed units. The only controls that may require periodic adjustment are accessible through the rear panel. Because extensive damage could result from attempts to measure circuit parameters or to trouble-shoot the meter by non-factory personnel, the warranty is voided if the unit has been removed from its case.

2.2 Installation-Mechanical

Drawing 03802 illustrates the detailed method of mounting the panel meters for each of the three mounting options. All critical dimensions are shown including those for the panel cutout.

<u>MOUNTING STYLE</u>	<u>DESCRIPTION</u>
---------------------------	--------------------

A1	Unit is mounted flush on studs behind a rack panel.
A2	Unit is mounted behind a rack panel by inserting the furnished 6-32 screws through the rack panel and into threaded holes in the case.
A3	Unit is mounted through the rack panel from the back and held in place from the rear by a "U" bracket. The mounting cutout is hidden by the instrument bezel.

2.3 INITIAL CHECKOUT PROCEDURE

1. Connect a voltage source (eg. power supply) between pins 9 and 10 on the upper (Analog) connector J2.
2. Connect a jumper between pins 7 and 9 on the same connector.
3. Connect a power cord to the upper (Analog) connector as follows:
 - A. To pins 1 and A connect the high or "hot" lead.
 - B. To pins 2 and B connect the low or "cold" lead.
 - C. To pins 3 and C connect the earth ground or "third wire".
4. Apply 115 VAC, $\pm 10\%$, 50-60 Hz to the power cord.
5. Adjust the input voltage source to be within the measurement range of the meter and verify that the meter is reading correctly.

CAUTION
Accidental connection of power to the
Digital Board can result in catastrophic failure

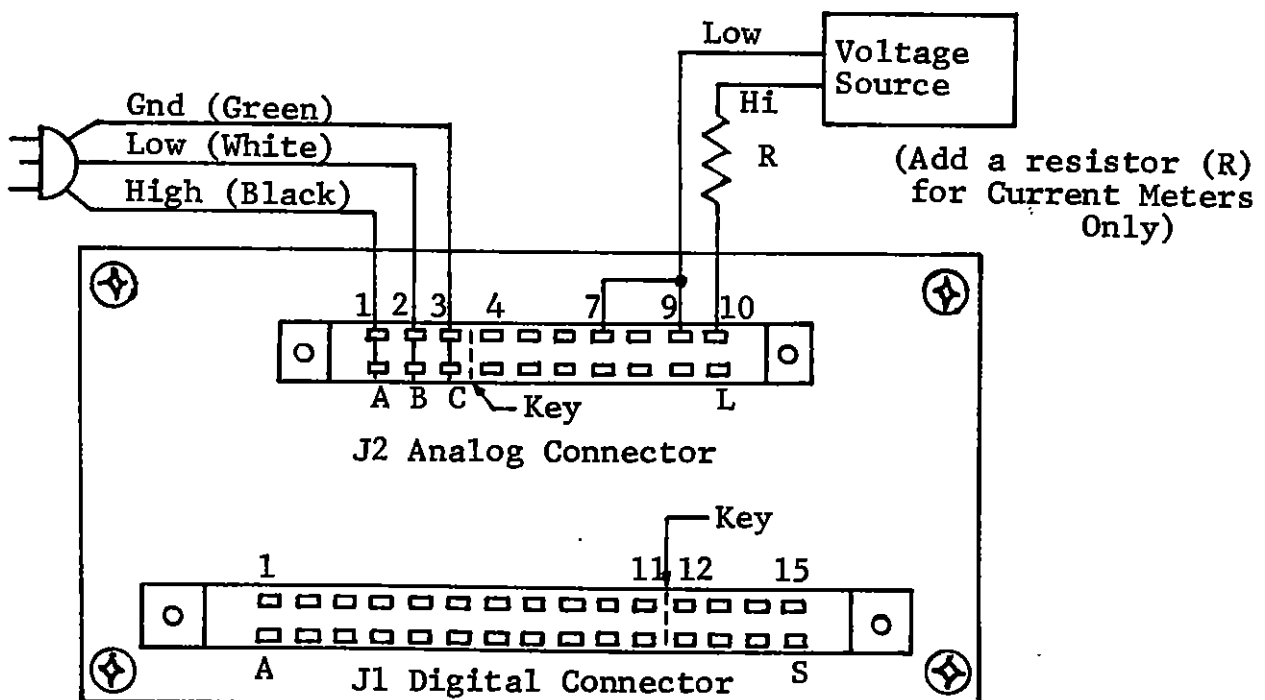

Figure 2-1 Rear-View Interconnect

SECTION 3
OPERATING INSTRUCTIONS

3.1 Power

Description

The standard meter operates from a 115v or 230v, $\pm 10\%$, 50-60 Hertz power source. It dissipates approximately 7 watts. It should be connected to the power source by a three conductor cable. Two conductors provide the power to the meter and the third provides safe grounding of the case. The third conductor should connect to earth ground at the power end of the cable and to the Analog Connector at the meter end of the cable. A wire from the Analog board to a locking terminal lug completes the connection to the case when the lug is secured by the rear panel screw.

CAUTION

Accidental connection of power to the Digital Board
may result in catastrophic failure.

Wiring Detail, 115 VAC Operation

The power cable is connected as follows to the top or Analog board. (This connector may be a single or double sided when operating on 115V only).

- (a) To Pins 1 and A connect the high or "hot" side of the 115v power line.
- (b) To Pins 2 and B connect the low or "cold" side of the 115v power line.
- (c) To Pins 3 and C connect the earth ground or "third wire".

Wiring Detail, 230 VAC Operation

The power cable is connected as follows to the top or Analog board.

- (a) To Pin 1 connect the high or "hot" side of the 230v power line.
- (b) To Pin 2 connect the low or "cold" side of the 230v power line.
- (c) Jumper Pin A to Pin B.
- (d) To Pins 3 and C connect the earth ground or "third wire".

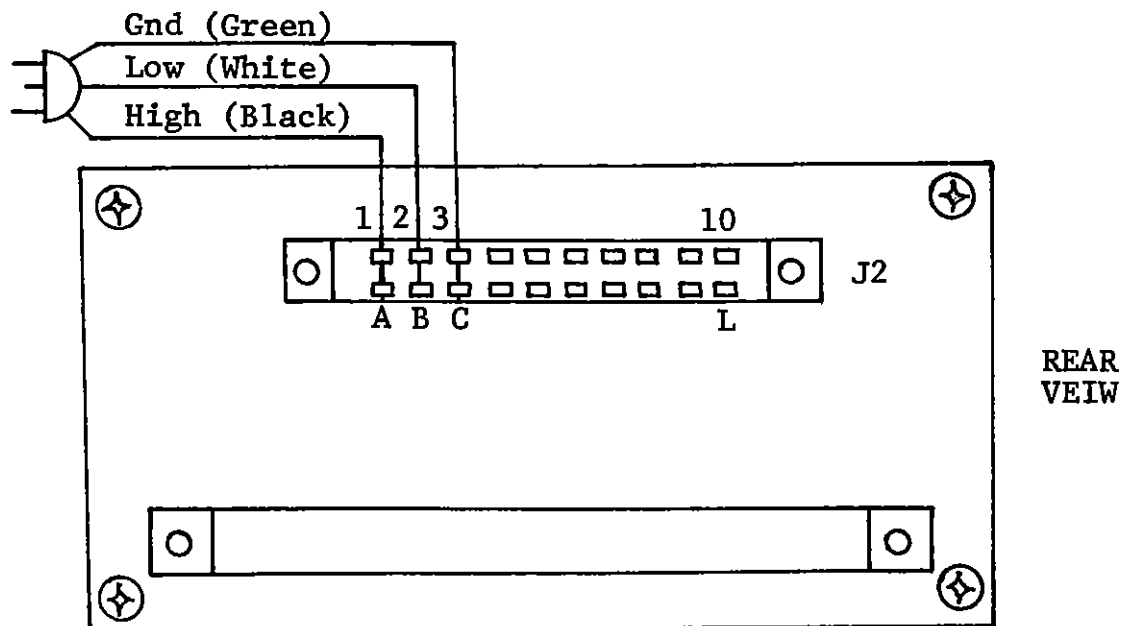

Figure 3-1 115 V ac Connection

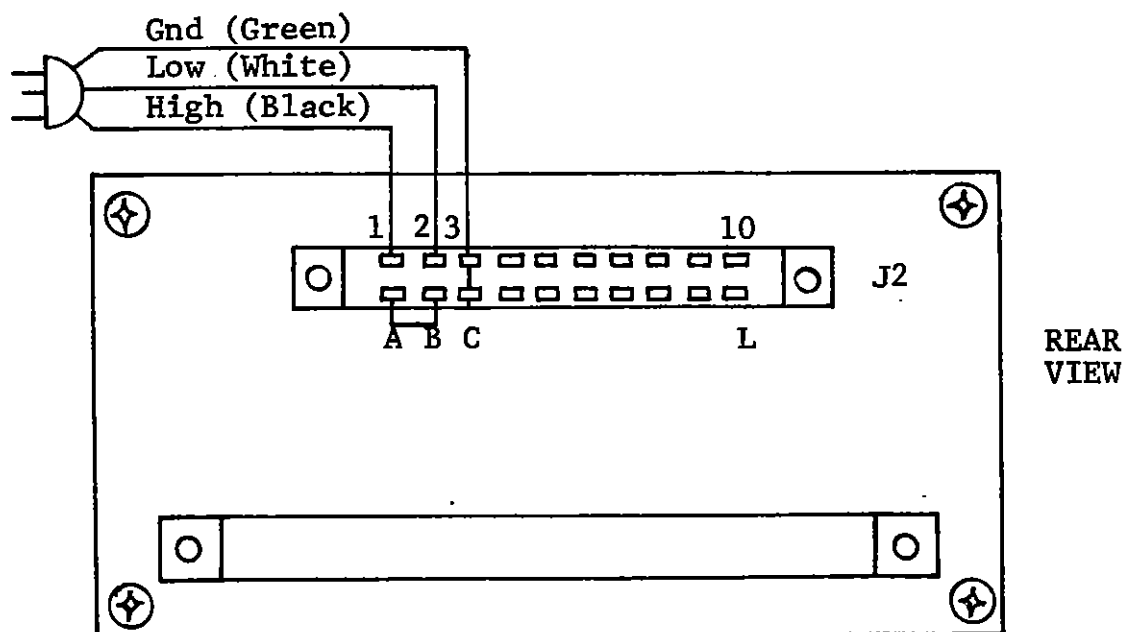

Figure 3-2 230 V ac Connection

Signal Inputs

Introduction

The 2000B/S series of panel meters employs a differential bipolar input circuit with 6 volts of common mode rejection between either input lead and circuit ground.

The input impedance for the 199.99mv and 1.9999v meters is 1000 megohms minimum. An input attenuator is added to produce the 19.99v and 199.9v meters. The input impedance of the attenuator is 10 megohms.

Description

The basic bipolar input is a differential input circuit with common mode isolation up to +6v between either input lead and circuit ground. The latter constitutes the reference ground for the external control and BCD output circuits. Floating inputs require the addition of an external common mode path between the input leads and circuit ground. For this reason a guard terminal with a one megohm resistor to circuit gnd is provided. Circuit ground is isolated with respect to the case or earth ground up to a potential difference of +300v.

Wiring Detail - Floating Input

When the input voltage source is completely floating from meter ground, the common mode voltage will exceed the 6v limitation due to the lack of a low impedance path for the input bias current between the input leads and circuit ground. The effect is for the readings to bounce erratically. To reduce the common mode voltage to less than 6v, pin 9 should be returned to circuit ground pin 7, directly or through the internal network on pin 8.

- (a) To Pin 10 connect the high side of the input signal.
- (b) To Pin 9 connect the low side of the input signal.
- (c) To Pin 8 (Guard) connect the meter end of the shield. Connect the other end of the shield to the low side of the source.
- (d) If the meter is used for visual readout only (eg. no external control) connect a jumper from pin 7 to pin 8.

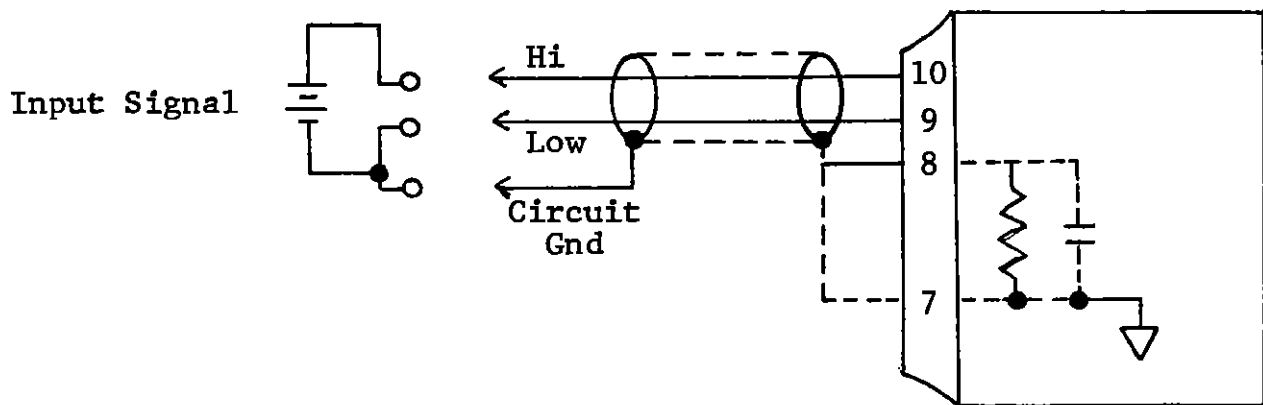

Figure 3-4 Input Signal Connections

On 200mV and 2V meters, the inputs are true differential. Therefore the high and low leads may be reversed to change the polarity indication.

Input Characteristics

Input Source Resistance

Maximum bias current for the 200mv and 2v meters is 10na. One digit of offset may be generated by input source resistances of 1K and 10K Ohm respectively. The error due to source resistance may be reduced by keeping equal resistances in both leads.

Input Filter

The standard input filter is a single section low pass filter having a cutoff frequency (-3db) of 8Hz. The settling time to .01% is 250ms.

The filter cutoff frequency may be factory altered by changing the value of a capacitor to provide either a shorter settling time for faster response or a lower cutoff frequency for better noise rejection.

Since the filter is connected directly to the input, any equivalent source impedance will act to lower the cutoff frequency and increase the noise rejection and settling time. By putting equal resistance in series with both inputs, input filter characteristics may be easily changed.

Digital Inputs/Outputs

The logic levels present at the digital connector are DTL and T²L compatible.

(a) Input Requirements:

Low level 0 to +.8v, sink 1.6ma
High level +2.0 to +5.0v, source .1ma

(b) Output Specifications:

Low level 0 to +.5, sink 10ma
High level +2.4 to +5.5v, source 6K Ohm

EXTERNAL CONTROL

The digital panel meter provides a choice of several external control modes. This choice of modes allows the meter to satisfy a wide variety of interface requirements when used as a systems component.

The meter has a basic read rate of 4 conversions per second, but is capable of making measurements at a maximum rate of 30 conversions per second when the 30Hz Read Rate input is grounded. Each conversion is synchronized to the 60 Hertz power line and always starts at the same point on the power line cycle. By means of external control any number of these cycles may be skipped with the meter retaining the reading corresponding to the last conversion. When the external command is given for a new reading the meter waits until the next synchronization point is reached on the power line cycle before starting the conversion.

The basic external control functions are labeled READ, DATA READY and BCD ENABLE. After the READ signal goes true (high) the meter starts a new conversion process at the next synchronization point on the cycle. At the conclusion of the conversion process and before the next synchronization point occurs, the DATA READY signal goes true (high). This indicates that the conversion process is complete and the information present on the data outputs is ready for use. With a low input on the BCD ENABLE input the BCD outputs will be held in the high state. The BCD ENABLE can be used to keep the BCD outputs from "RUNNING" during conversion or to enable the BCD output of one meter at a time while digitally multiplexing many parallel wired DPM's.

A test input is provided which, when connected to digital ground causes the indicators to display all segments. This input is also the +5V output for logic tie points (eg. BCD enable) and will supply 2mA max.

3.4.1

READ

The READ input controls the start of each conversion process. A high level (or open) enables and a low level disables the conversion process.

An internal storage element allows one more reading to occur after the READ input goes low. When this is undesirable an internal jumper on the digital board may be cut to disable the storage feature.

Operation with Storage Jumper

The meter is normally furnished with the storage jumper. The application of a high input sets the storage element, which then remains set after the READ input goes low. The storage element is reset by the start of the next conversion cycle. The effect is to provide one more measurement after the READ input goes high. The following modes of operation exist with the storage jumper in place.

Level Mode

While the READ input is maintained true (high), measurements occur at the selected reading rate. While it is false (low), the last measurement made is held in memory. One more measurement is made after the READ input goes low. It is this measurement that is held in memory as long as the READ input remains false.

Pulse Mode

A pulse that goes high at the READ input for a minimum of two microseconds and terminates before the next synchronization point on the power line cycle will set the storage element and provide one conversion starting at the synchronization point. If the pulse extends beyond the synchronization point, an additional conversion will occur. To insure that only one conversion is made, the pulse width must be less than 300 microseconds.

Operation Without Storage

There are applications (eg. when the BCD outputs are connected to a printer) for which it is desirable to disable the storage function. This is accomplished by cutting or removing jumper W2 on the digital board. This insures that when the READ input goes low, no more conversions take place and the BCD outputs remain static for use by an external device.

Wiring Detail

The READ input signal is connected to the bottom (Digital) board.

- (a) To Pin 13 connect the high side of the input.
- (b) To Pin S connect the low side or ground return of the READ input.

3.4.2 DATA READY

The DATA READY signal goes true (high) to indicate the completion of a conversion process and remains true until the next conversion process is started. During this time the BCD outputs represent the value of the measurement and are available for use by an external device. The DATA READY signal normally remains true for at least 20 milliseconds but this time may be extended indefinitely with a low level on the Read input.

Wiring Detail

The DATA READY, connection is available on the bottom (Digital) board.

- (a) Pin 14 - DATA READY output signal.
- (b) Pin S - Ground reference for the DATA READY output signal.

3.4.3 +5V (TEST)

This pin supplies either a 5V tie point for unused inputs or if grounded will light all readout segments.

Wiring Detail

The +5V (TEST) connection is available on the bottom (Digital) board.

- (a) 5V Tie Point: Connect to Pin N.
- (b) Test Readout: Connect momentarily Pin N to Pin S.

3.4.4 BLANKING

Provision is made internally to blank the four least significant digits at overload. External blanking of all five digits can be implemented by connecting the overload output to the blanking input.

Wiring Detail

The blanking connections are available on the bottom (Digital) connector.

- (a) Internal blanking only (overload) - Pin 15 ground or open.
- (b) External blanking of all five digits - Pin 15 to +5V.
- (c) Overload blanking of all five digits - Pin 15 to Pin 11.

3.4.5 DECIMAL POINTS

All four of the numerical readout tubes contain a left-hand decimal point which may be lighted to provide the proper decimal point representation of the quantity being measured. All four decimal points are available at the connector and may be individually selected by external circuitry.

Wiring Detail

The decimal point locations are designated by representing the four full decimal digits by X's and placing the decimal point in the position corresponding to its display location. The decimal point connections are available on the bottom (Digital) board.

- (a) Pin 3 - Decimal Point LXXX.X
- (b) Pin E - Decimal Point LXX.XX
- (c) Pin 8 - Decimal Point LX.XXX
- (d) Pin L - Decimal Point 1.XXXX
- (e) Pin S - Ground reference

Any decimal point may be lighted by connecting the designated pin to ground, Pin S, either with a jumper or through relay contacts. A solid state switch could also be used if it is rated for 3ma in the ON state and is capable of blocking 70 volts with a leakage of less than 1 microampere in the OFF state.

3.4.6 BCD OUTPUTS

Positive true BCD outputs representing each digit of the readout as well as OVERLOAD and POLARITY are standard. The OVERLOAD output goes true when the input voltage exceeds the full scale rating of the meter. The Positive Polarity output goes true when the polarity of the input signal is positive.

The BCD, POLARITY, and OVERLOAD outputs are settled and ready for acceptance by an external device when the DATA READY signal goes true. The data may be held indefinitely by maintaining a low level at the READ input.

The BCD outputs of the Series 2000B/S are buffered and gated. Connecting a low signal to BCD ENABLE Pin 12 causes all the BCD outputs to go high. The gated BCD lines from several meters may be multiplexed by parallel wiring the outputs. By sequentially enabling each meter its BCD outputs will appear on the common buss. The BCD ENABLE can also be used to gate the BCD outputs off during the conversion period. This is recommended to reduce "noise" on the BCD outputs during the conversion period.

Wiring Detail

BCD Output

This data is on the bottom connector. The pin designations are listed on the pin assignment list. Digital ground, pin S should be used as the common reference for these signals.

BCD Enable

- (a) Pin 12 BCD ENABLE input-low to disable BCD outputs. Connect to +5V (pin N) when using BCD outputs.
- (b) Add a jumper from pin 14 (DATA READY) to pin 12 to gate off BCD output during conversion.

3.5 2000B/S Pin Assignments

J2 - Analog Board Upper Connector

<u>PIN NO.</u>	<u>NAME</u>	<u>DESCRIPTION</u>
10,L	SIG HIGH	Signal high input
9,K	SIG LOW	Signal low input
8,J	GUARD	Provides bias current return for input amp
7,H	CIRCUIT GND	Meter Circuit Ground
6,F 5,E 4,D	SPARES	No internal connection on standard meter.
3,C	POWER GND	Case & third wire gnd.
2	INPUT POWER LO	115/230 input (connect to "B" for 115V)
1	INPUT POWER HI	115/230 input (connect to "A" for 115V)
B	INPUT VOLTAGE SELECT	Jumper to "2" for 115V or to "A" for 230V
A	INPUT VOLTAGE SELECT	Jumper to "1" for 115V or to "B" for 230V

NOTE: If operating from 115V AC only, a 10 pin single row connector may be used for J2.

2000B/S PIN ASSIGNMENTS

J1 - Digit Board Lower Connector

<u>PIN NO.</u>	<u>NAME</u>	
13	READ	Open to read, ground to hold
R	30/SEC	Open for 4 readings per second. Ground for 30 readings/second.
N	+5V & TEST	+5V @2ma, ground for Test
S	CIRCUIT GND	Reference ground for all digital input and outputs
14	DATA READY	Low during conversion
3	UNITS DP	Gnd to light decimal point at 1XXX.X
E	TENS DP	Gnd to light decimal point at 1XX.XX
8	HUNDREDS DP	Gnd to light decimal point at 1X.XXX
L	THOUSANDS DP	Gnd to light decimal point at 1.XXXX
12	BCD ENABLE	+5V for normal BCD output, low to force BCD outputs high.
15	BLANKING	+5V to blank display, ow or open for normal operation

A - 1 BIT
 B - 2 BIT
 2 - 4 BIT
 1 - 8 BIT
 4 - 10 BIT
 5 - 20 BIT
 D - 40 BIT
 C - 80 BIT
 F - 100 BIT

H - 200 BIT
 7 - 400 BIT
 6 - 800 BIT
 9 - 1K BIT
 10 - 2K BIT
 K - 4K BIT
 J - 8K BIT
 M - 10K BIT
 11 - OVERLOAD
 P - POSITIVE POL

Isolated, Gated,
 BCD Outputs
 Positive True

SECTION 4

THEORY OF OPERATION

4.1 General

The Series 2000B/S digital panel meters basically accept DC analog voltages at their input and display the value digitally with planar gas discharge cold-cathode glow tubes. The value is also available electrically in BCD form at the digital connector. The inputs to the 200mv and 2v full scale meters are connected directly to the input amplifier. The 20v and 200v full scale meters are basic 2v meters with a 10:1 and a 100:1 attenuator respectively. The current meters are basic 200mv full scale meters with a shunt dropping resistor across the input.

4.2 Timing

The conversion process is synchronized to the 60 Hz power line as shown in the timing diagram below. Conversion takes place during the negative portion of the cycle. During the positive half cycle the reading is held and the half-wave rectified high voltage is applied to the display anodes.

The reference current is integrated for a period of time proportional to the reading. It is zero for a reading of zero, 6ms for a reading of full scale or greater.

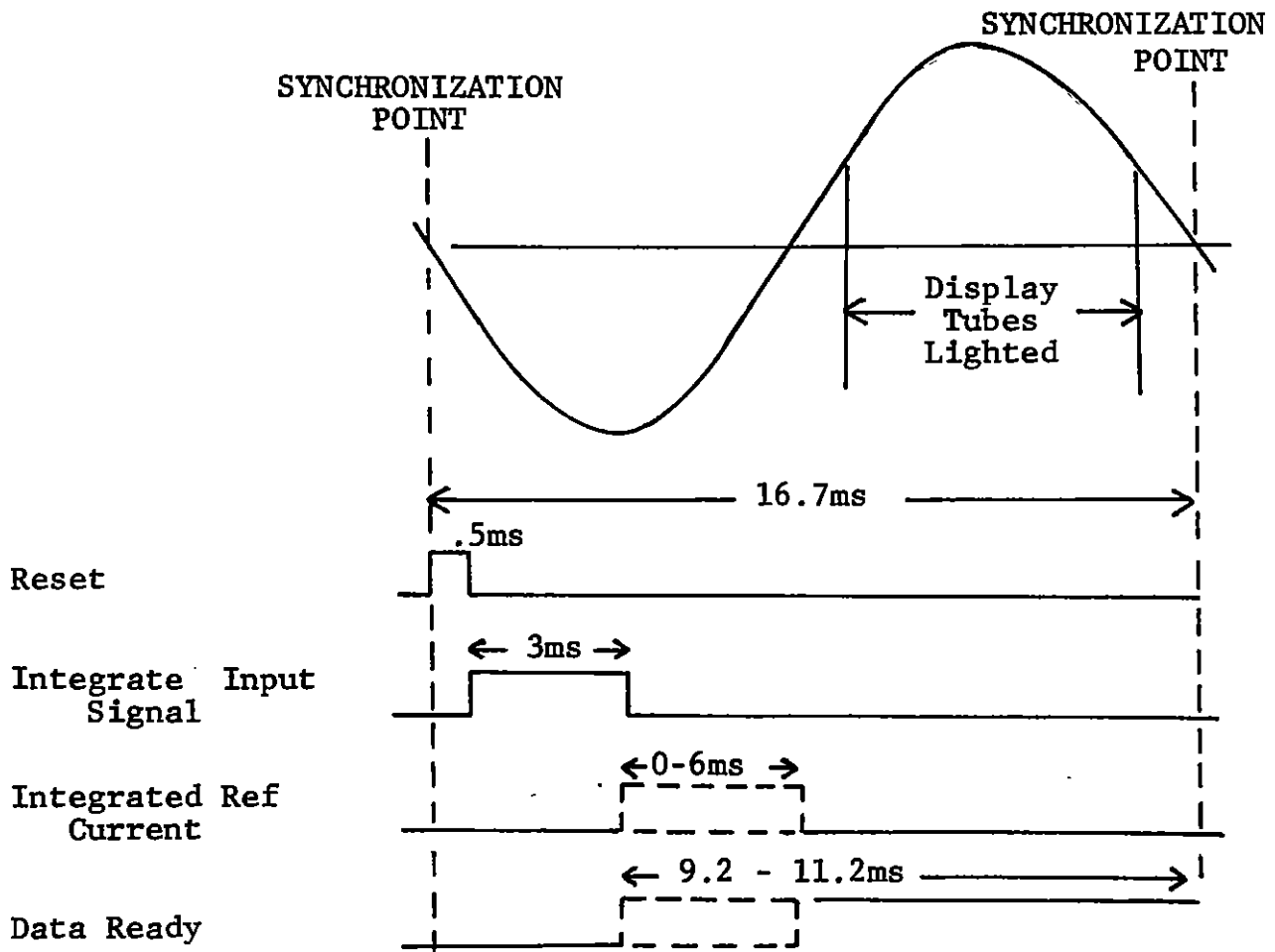

Figure 4-1 Simplified Timing Diagram

Refer to the simplified block diagram (figure 4-2) and basic timing diagram (figure 4-1).

The measurement cycle begins when the reset circuit detects the zero crossing of the falling edge of the AC line and generates a reset pulse. This reset pulse sets the BCD counter to a count of 00000 and sets the I-SW flip flop to the Signal Integrate state. The I-SW flip flop output causes the current switch to switch the signal current sink to the integrating capacitor and turns the gated oscillator on. When the integrating capacitor begins to charge down, the clamping comparator output goes high.

When the BCD counter reaches 10000 counts the I-SW flip flop is set to the Reference Integrate state, causing the current switch to select the reference current source. At this time the BCD counter is at 00000 counts because the 10K flip flop J terminal was false. The integrating capacitor discharges at a constant rate back to its initial charge at which time the clamping comparator goes low, turning the gated oscillator off. The number of counts now in the BCD counter is equal to the input voltage and the data ready signal goes true. The display is turned on each half cycle during the time data is stable.

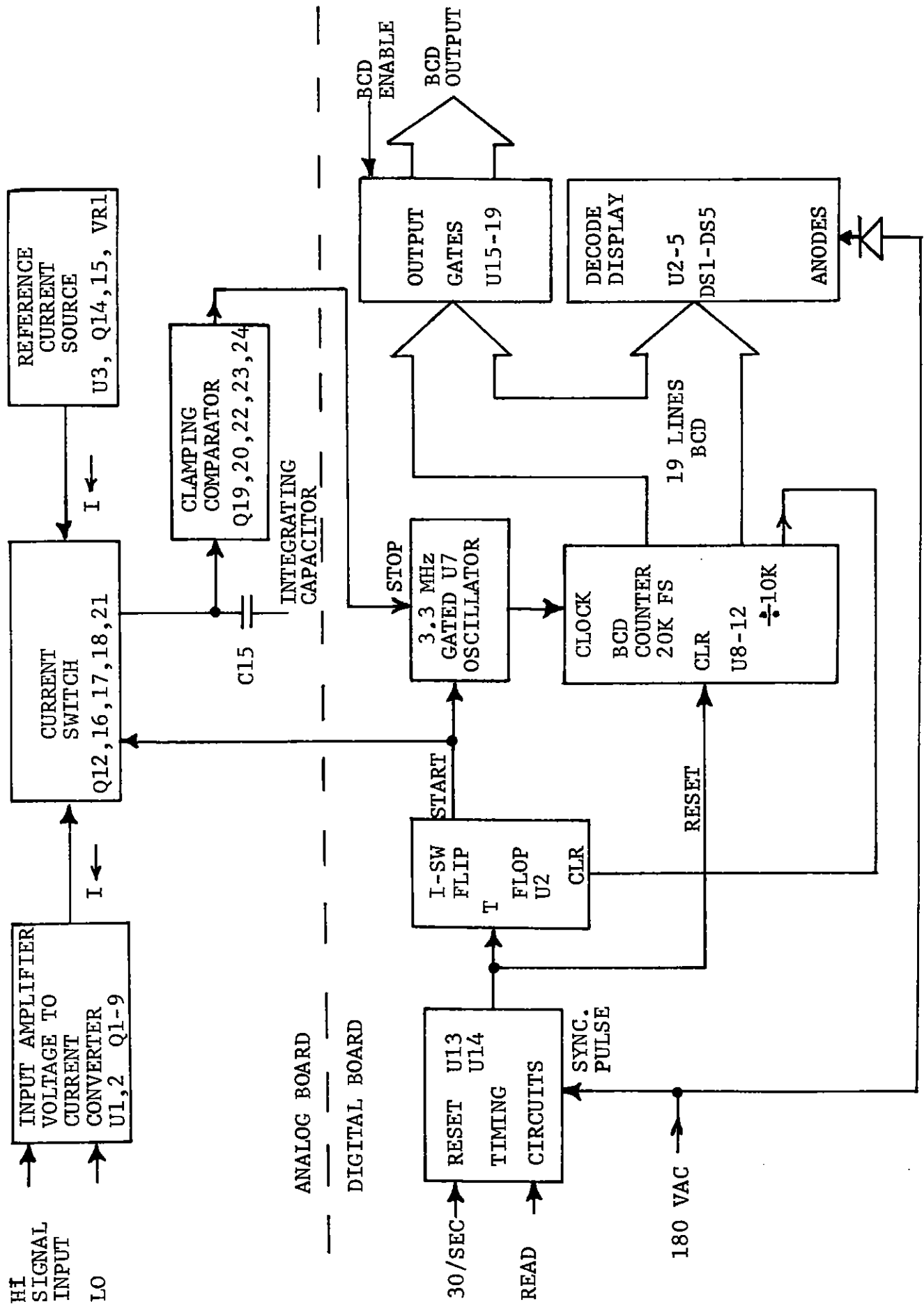

Figure 4-2 Simplified Block Diagram

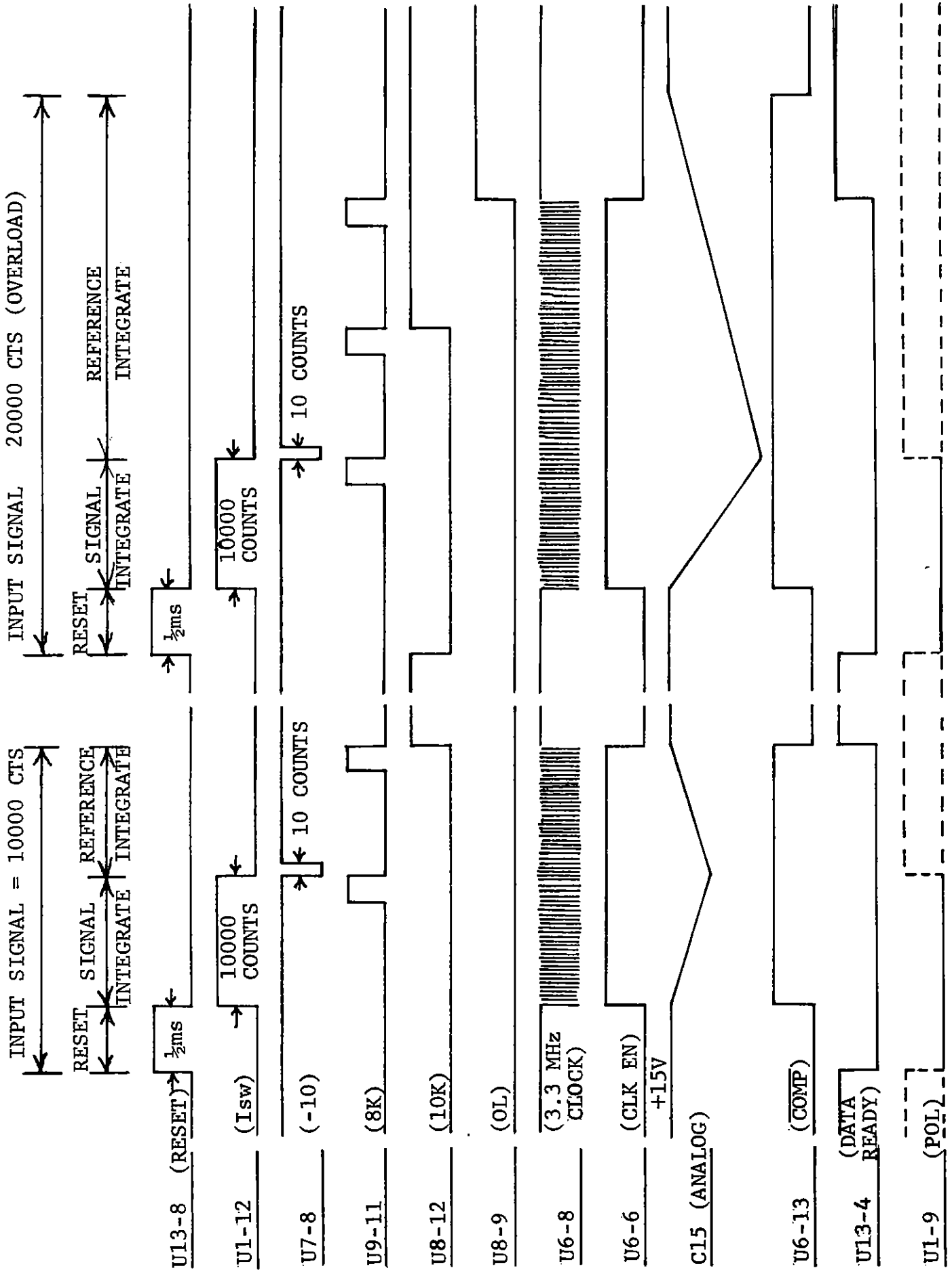

Figure 4-3 Timing Diagram 2000BS

SECTION 5

MAINTENANCE AND CALIBRATION

5.1 Introduction

There are four adjustments available on the basic digital panel meter. These are the Zero adjustment, the Full Scale adjustment, the \pm Gain adjustment and the Zero Width adjustment. These controls are located at the rear of the meter.

All controls should be adjusted with an insulated screwdriver according to the following instructions. Always allow at least 30 minutes warm-up time before making the adjustments.

5.2 Calibration (Recommended interval 60-120 days)

5.2.1 TEST EQUIPMENT REQUIRED

Variable voltage (current) standard with an accuracy of .003% such as a Fluke model 343A.

5.2.2 SET UP

Use "Initial Checkout Procedure" at front of manual.

5.2.3 CALIBRATION ADJUSTMENTS

- (a) With the input leads shorted together, adjust R9 "ZERO" to the position where the polarity sign just switches from minus to plus.
- (b) With an input signal of 10 counts (ie 1.0mv for a 2v meter) adjust R29 "ZERO WIDTH" for a readout centered on 0010.
- (c) Apply a signal near full scale and note the readout, then reverse the polarity and if the readout is not the same adjust R17 " \pm GAIN" to take up half the difference. Repeat until the readout is the same in both polarities.
- (d) Apply a known signal near full scale in either polarity (ie 1.5 to 1.9v for a 2v meter) and adjust R34 "FULL SCALE" for the correct readout.

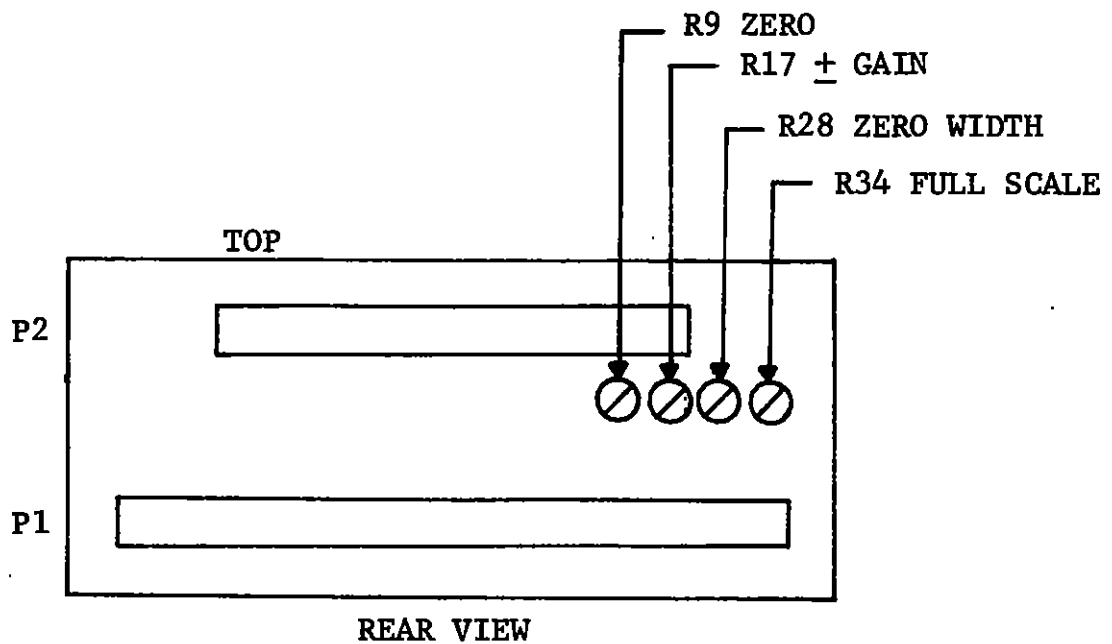

Figure 5-1 Rear-View Calibration Adjustment Location

5.3 Maintenance & Repair

Due to the complex operation of this instrument and special laboratory test equipment needed to repair it, no attempt should be made to troubleshoot the circuit cards in the field by untrained personnel.

Before returning the instrument to the factory, every attempt should be made to insure that the instrument is actually at fault and that the trouble is not in the set up. The best way to insure this is by substituting a known working instrument. Alternately, the meter should be removed from the set up and tested by using a battery or power supply as an input source.

If the instrument is found to be at fault, please fill out the Returned Material Authorization and return with the unit. The best way to insure that the defect will be quickly found and repaired is to include a diagram of your actual test conditions, so that the factory will be able to duplicate the failure easily.

If customer repair is to be undertaken, the following guide will assist in the tracing of a fault to a functional area of the meter.

Test 1

After determining that the power supplies are furnishing the correct voltages, hook up the meter per the Initial Checkout Procedure. Apply a positive and then a negative voltage to the input terminals. If the + and - indicators do not follow the input signal, look at the logic level on U1 pin 7 (Digital). If this signal does not follow the polarity of the input signal, the trouble is likely in the input amplifier circuitry on the analog board.

Test 2

If the signal at U1 pin 7 (Digital) is correct, ground U6 pin 13 (Digital). The readout should be 00000.

Test 3

Remove the ground from U6 pin 13 (Digital) and ground P1 pin N. The readout should light all segments (18888). If this test or test 2 produces incorrect results the trouble is on the digital board.

Using the results of these tests, the simplified block diagram, Figure 4-2, will assist in tracing the malfunction to a functional block of the meter.

Test 1 indicates if the input amplifier is following the input signal polarity. Test 2 simulates a comparator input to the digital circuitry as if the analog board was working with zero input. Test 3 simulates no comparator input to the digital circuitry as if the analog board was working with an overloaded input. If all three tests give correct results, look for the trouble in the reference current source or the current switch circuits. Look at the top of C15 with a 10M Ohm probe for a full scale input signal. A waveform should be observed ramping from approximately +14V to a point several volts lower during the time the signal at U1 pin 12 (Digital) is at a positive level (Signal Integration Time) and then ramping back up when the signal at U1 pin 12 is at a low level (Reference Integration Time).

DWG. NO.
03813AY-01 C

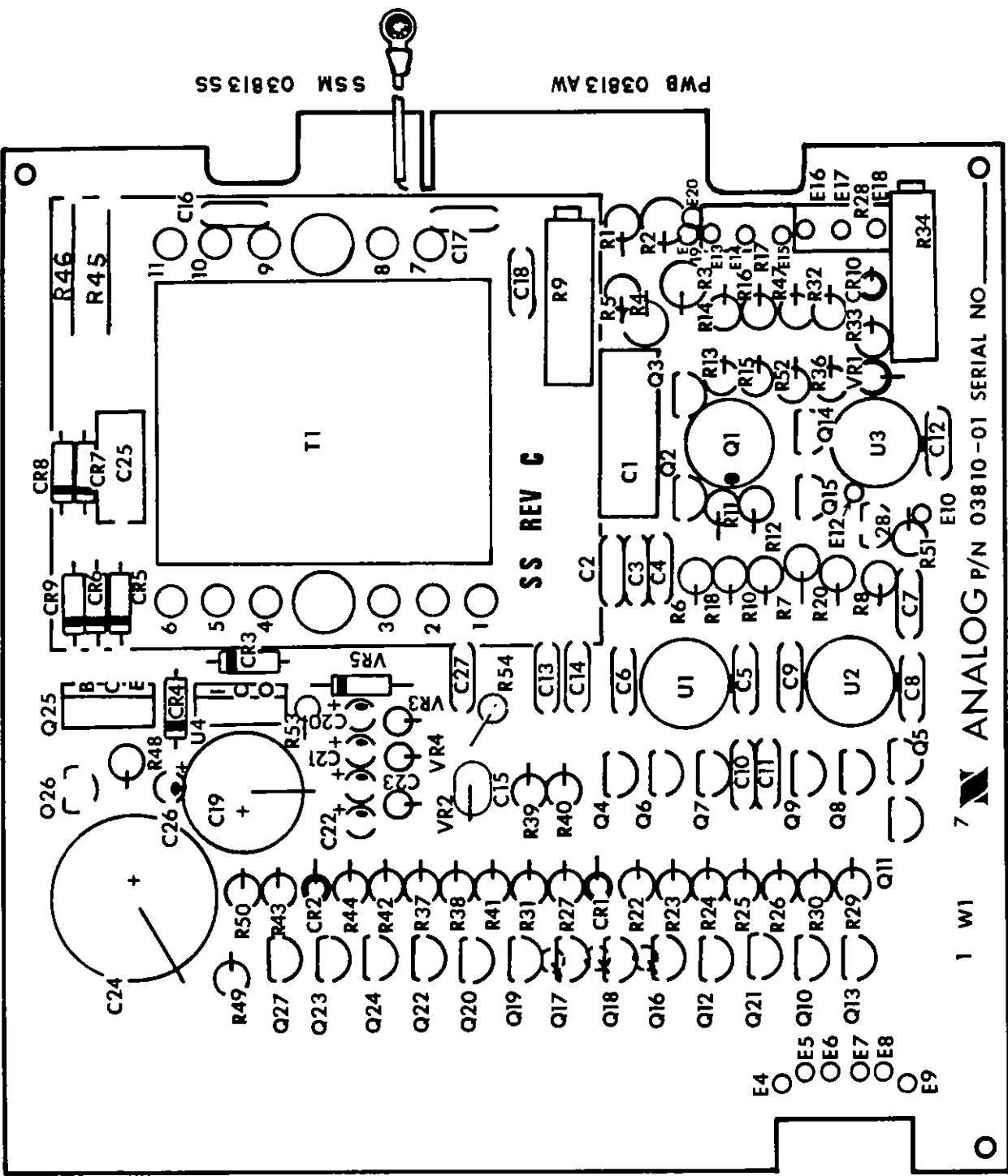

PCB ASSY DWG, 2000B/S ANALOG

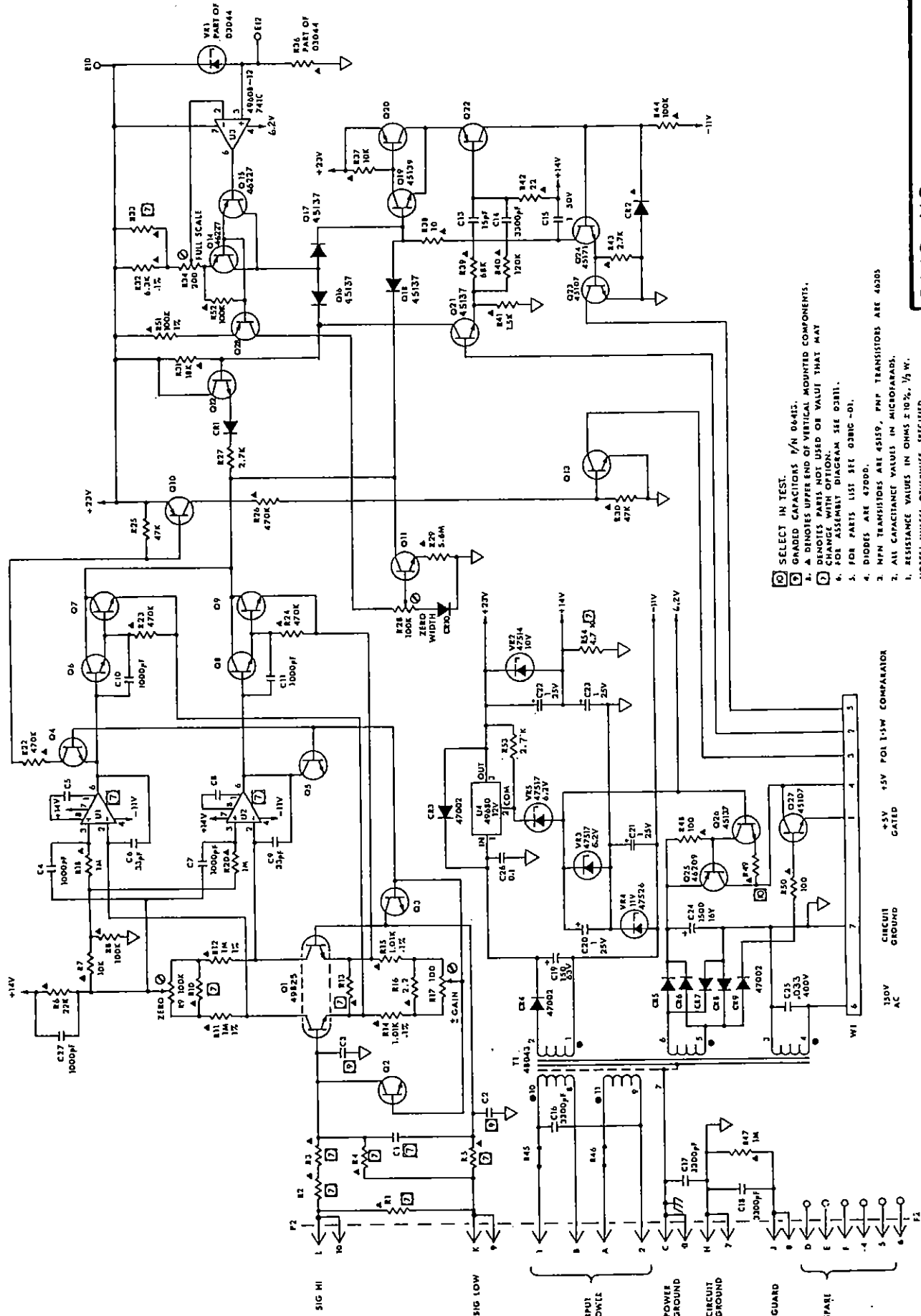

- [] SELECT IN TEST.
 [] GRATED CAPACITORS 1/N 04415.
 [] DIODES UPPER END OF VERTICAL MOUNTED COMPONENTS.
 [] RESISTOR PART NOT USED OR VALUE THAT MAY CHANGE WITH OPTION.
 [] FOR ASSEMBLY DIAGRAM SEE D3811.
 [] FOR PARTS LIST SEE D3810-D1.
1. RESISTANCE VALUES IN OHMS ± 10%, 1/2 W.
 2. MFM TRANSISTORS ARE 45159, PNF TRANSISTORS ARE 46005.
 3. ALL CAPACITANCE VALUES IN MICROFARADS.
 4. DIODES ARE 67000.
 5. RESISTANCE VALUES IN OHMS ± 10%, 1/2 W.
- NOTES: UNLESS OTHERWISE SPECIFIED

DWG. NO. 03812 W

SCHMATIC DIAGRAM 2000B/S ANALOG

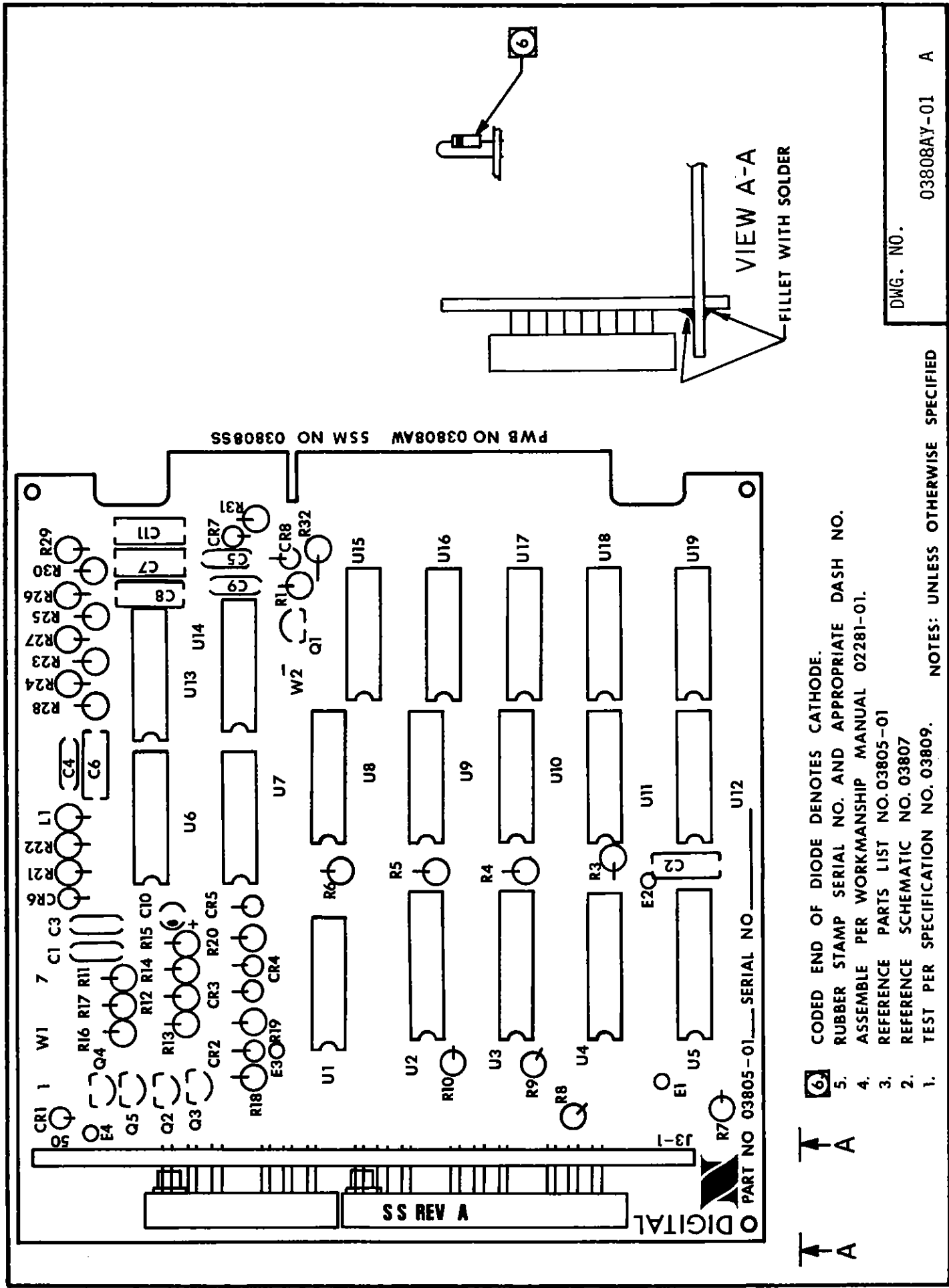

PWB NO 03808AW SSM NO 03808SS

- 6 CODED END OF DIODE DENOTES CATHODE.
- 5 RUBBER STAMP SERIAL NO. AND APPROPRIATE DASH NO.
- 4 ASSEMBLE PER WORKMANSHIP MANUAL 02281-01.
- 3 REFERENCE PARTS LIST NO. 03805-01
- 2 REFERENCE SCHEMATIC NO. 03807
- 1 TEST PER SPECIFICATION NO. 03809.

NOTES: UNLESS OTHERWISE SPECIFIED

DWG. NO. 03808AY-01 A

PCB ASSY DWG, 2000B/S, DIGITAL

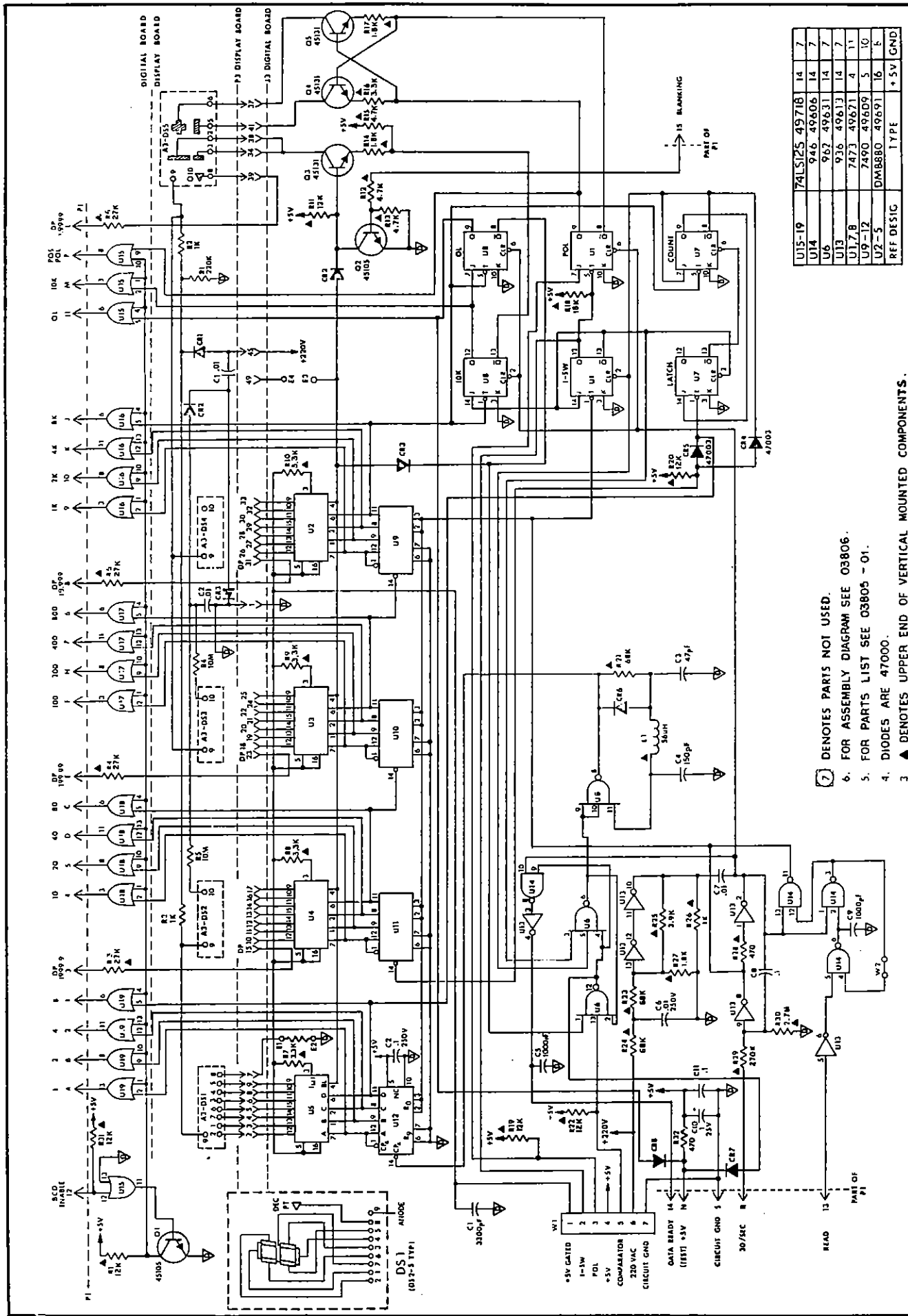

REF	DESIG	TYPE	1	6	10	14	7
U15-19	74LS125	4971B	14	7			
U14	946	49606	14	7			
U6	967	49631	14	7			
U13	936	49613	14	7			
U17,8	7473	49671	4	11			
U9-12	7490	49609	5	10			
U2-5	DMB880	49691	16	6			

DWG. NO. **03807** J

- 7 DENOTES PARTS NOT USED.
 - 6. FOR ASSEMBLY DIAGRAM SEE 03806.
 - 5. FOR PARTS LIST SEE 03805 - 01.
 - 4. DIODES ARE 47000.
 - 3 ▲ DENOTES UPPER END OF VERTICAL MOUNTED COMPONENTS.
 - 2. ALL CAPACITANCE VALUES MICROFARADS.
 - 1. RESISTANCE VALUES IN OHMS ±10%, 1/2 W.
- NOTES: UNLESS OTHERWISE SPECIFIED

SCHEMATIC DIAGRAM 2008B/S DIGITAL

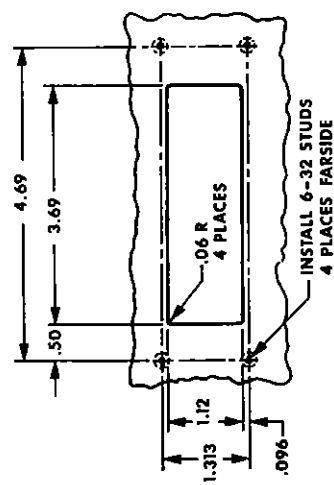

RECOMMENDED PANEL CUTOUT

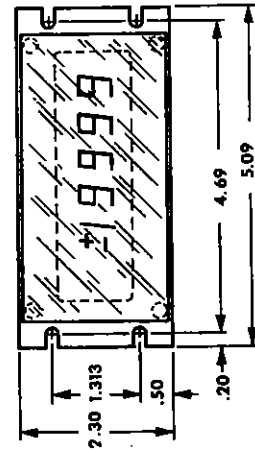
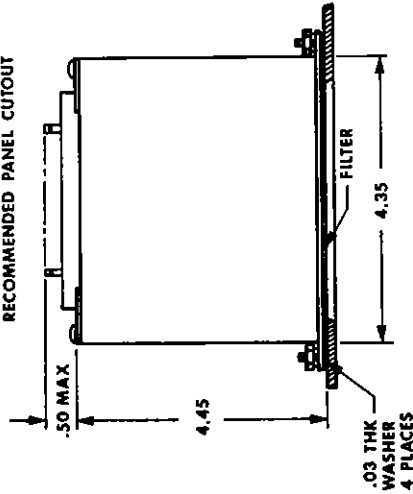

MOUNTING METHOD A1

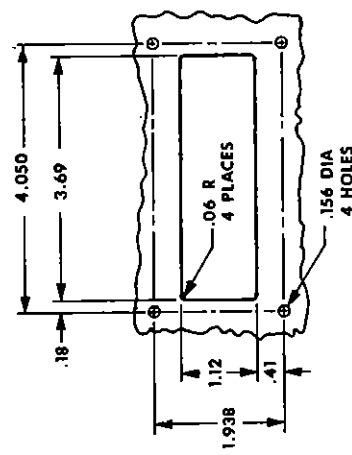

RECOMMENDED PANEL CUTOUT

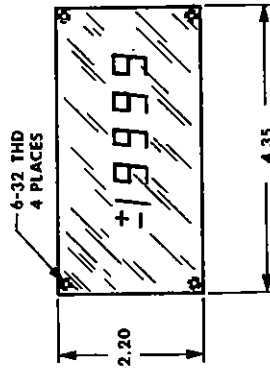
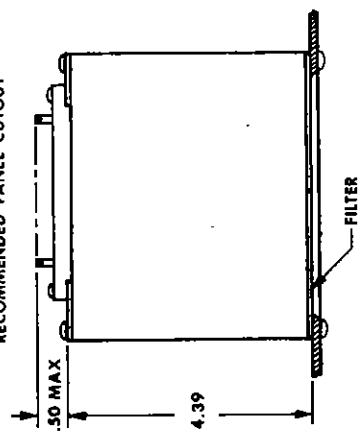

MOUNTING METHOD A2

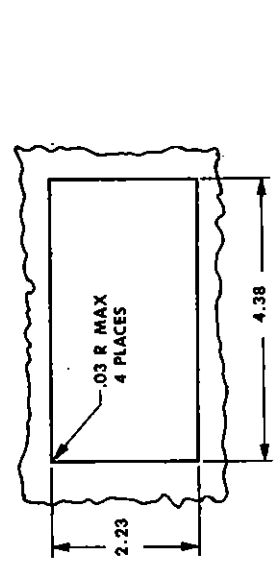

RECOMMENDED PANEL CUTOUT

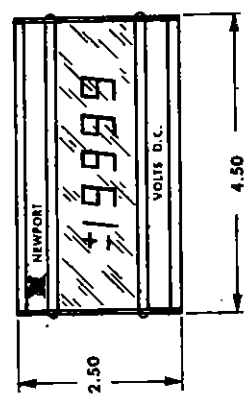
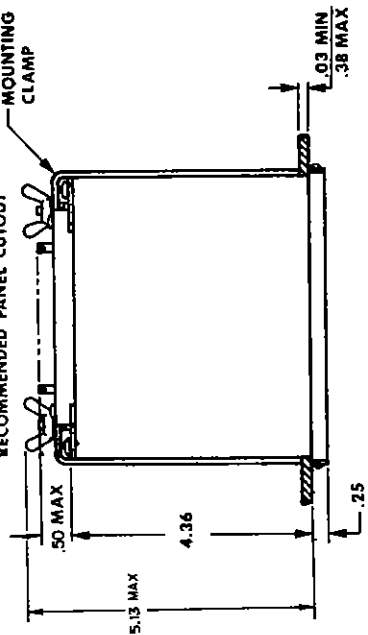

MOUNTING METHOD A3

OUTLINE AND MOUNTING A1, A2, A3 SERIES 2000B/S

1. REF: OWNERS MANUEL 03110 .
NOTES: UNLESS OTHERWISE SPECIFIED

DWG NO. 03802 A