

iSERVER - ADDENDUM
For zCDR



These changes are the result of the following product enhancement:

New case mounting design.

This addendum applies to Part 2 Hardware in your zSeries Operator's Manual.



2.0 HARDWARE

2.6 Dimensions and Mounting - Coordinator

Position unit where required. Mark and drill the two #6 screw holes.

After bracket is mounted on the wall, align back of unit over the three bracket clips, once engaged, slide downward, the unit will snap in place.

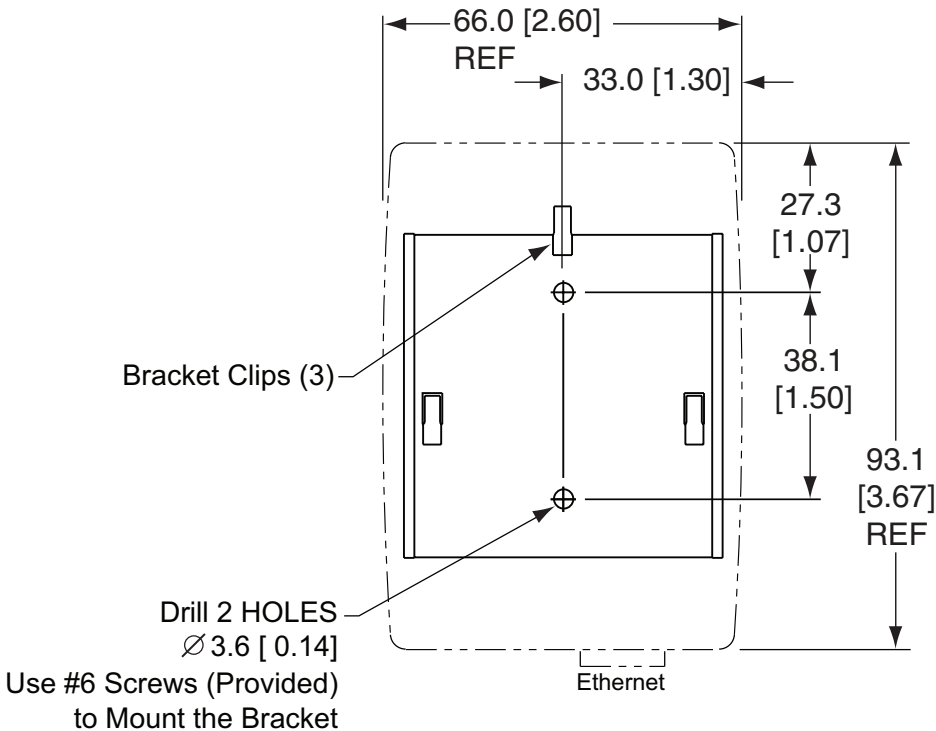
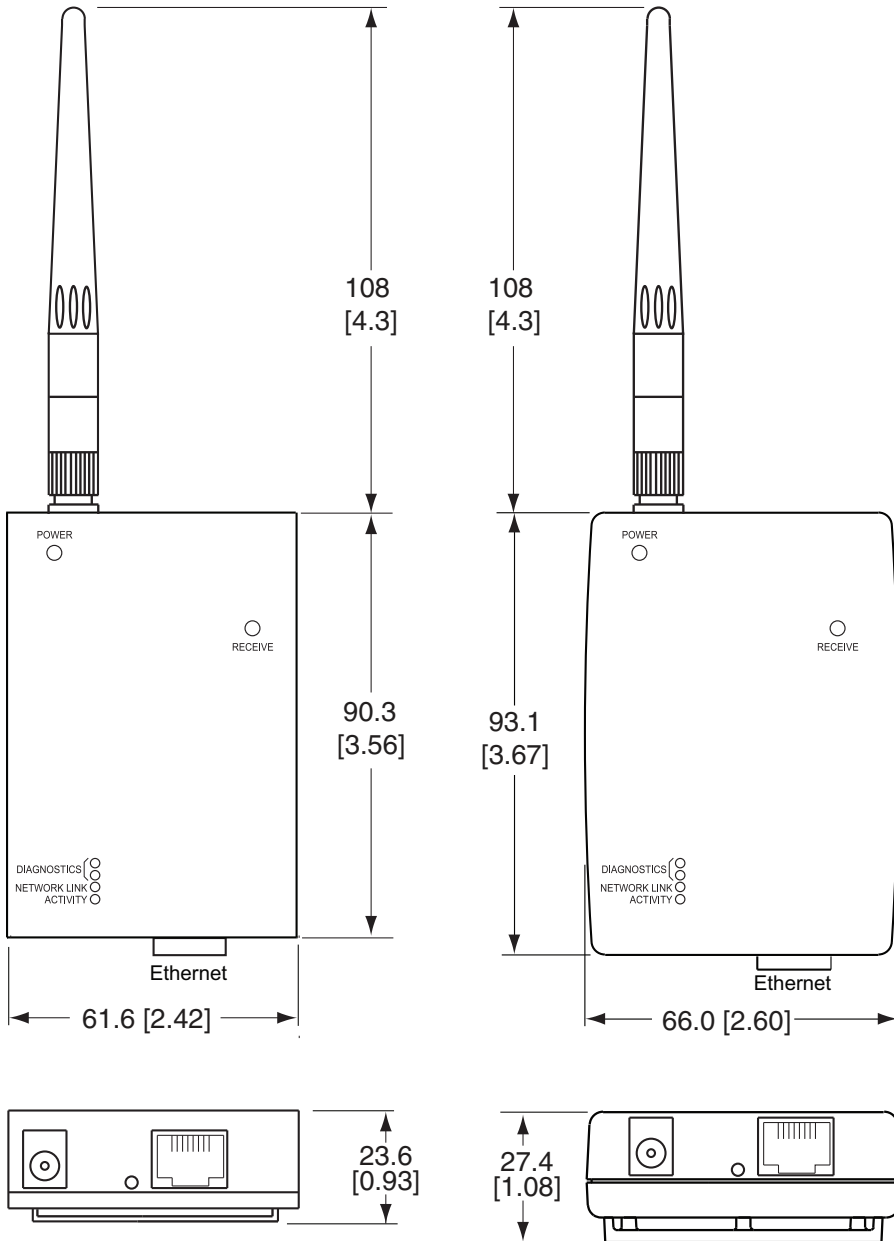

Figure 2.6a Mounting the Coordinator



If unit is to be mounted on a flat surface, you may take the bottom rubber feet off the unit.

2.6 Dimensions and Mounting - Coordinator (continued)



Version A - older case style

Version B - new case style

Figure 2.6b Coordinator Dimensions